



MICRO

TITAN

TPH

TPS

TPSP

TPF

TPK

TPC

TPCT

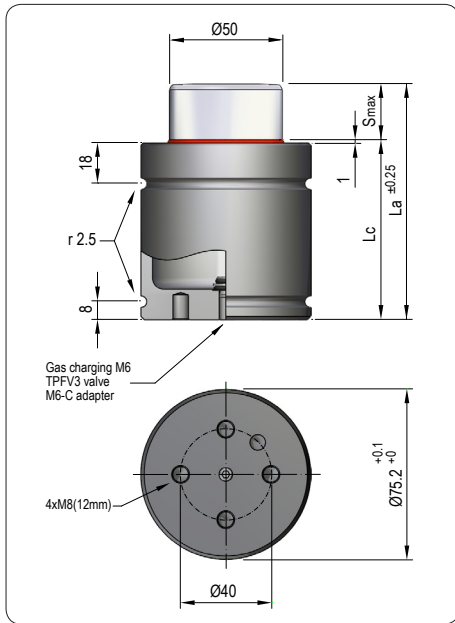

Pressure medium	Gas Nitrógeno (N <sub>2</sub> )
Max. charging pressure	150 Bar
Min. charging pressure	35 Bar
Rod seal area	19,63 cm <sup>2</sup>
Operating temperature	0°C - 80°C
Force increase by temperature	0,33 %/°C
Max. stem speed	0,8 m/s
Maintenance kit	Kit CT2500



VDI SAFETY

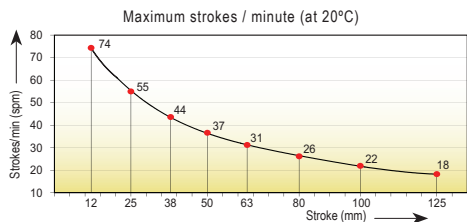

Code	S <sub>max</sub> mm	L <sub>a</sub> mm	L <sub>c</sub> mm	F <sub>a</sub> daN	90% F daN	100% F <sub>c</sub> daN	P Bar	V l	Kg
TPCT 2500x12	12	78	66	2500 ±5% (20°C)	3950	4220	127 (20°C)	0,058	1,60
TPCT 2500x25	25	104	79		4090	4400		0,113	1,90
TPCT 2500x38	38	130	92		4140	4470		0,169	2,05
TPCT 2500x50	50	154	104		4165	4500		0,220	2,30
TPCT 2500x63	63	180	117		4180	4520		0,276	2,55
TPCT 2500x80	80	214	134		4195	4540		0,349	2,95
TPCT 2500x100	100	254	154		4205	4550		0,434	3,25
TPCT 2500x125	125	304	179		4355	4745		0,517	3,70

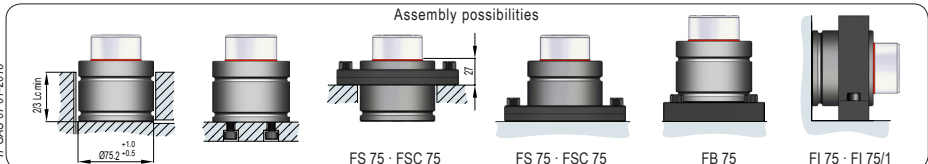
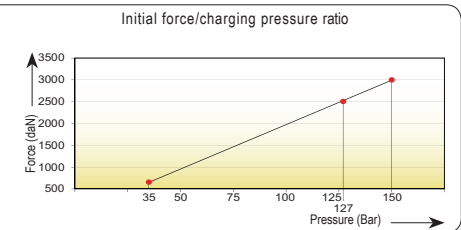
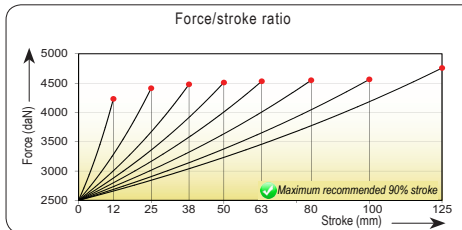

TPGAS 07-01-2018