

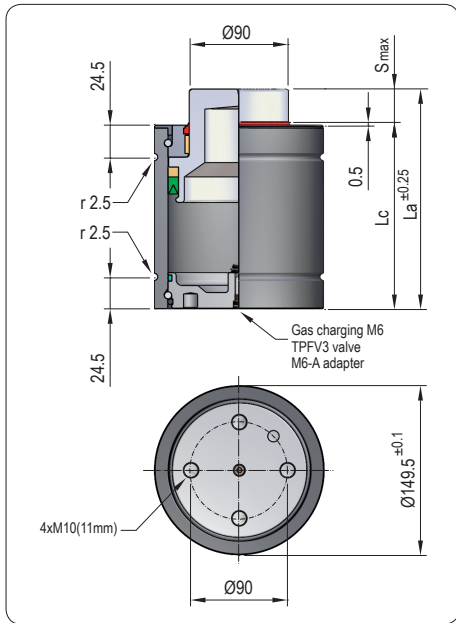

- MICRO
- TITAN
- TPH
- TPS
- TPSP
- TPF



Pressure medium	Gas Nitrógeno (N <sub>2</sub> )
Max. charging pressure	150 Bar
Min. charging pressure	50 Bar
Piston seal area	122.72 cm <sup>2</sup>
Operating temperature	0°C - 80°C
Force increase by temperature	0,33 %/°C
Max. stem speed	25 m/min
Maintenance kit	Kit F18300



VDI SAFETY

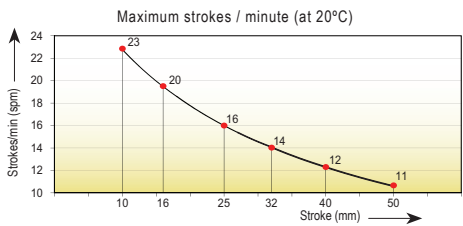

Code	Smax mm	La mm	Lc mm	Fa daN	90% F daN	100% Fc daN	P Bar	V l	Kg
TPF 18300x10	10	110	100	18300 ±5% (20°C)	22980	23630	150 (20°C)	0,555	9,10
TPF 18300x16	16	136	120		23800	24600		0,780	9,95
TPF 18300x25	25	165	140		24930	25950		1,055	10,80
TPF 18300x32	32	197	165		24710	25690		1,385	13,26
TPF 18300x40	40	235	195		24485	25415		1,780	15,10
TPF 18300x50	50	270	220		24890	25905		2,120	16,80

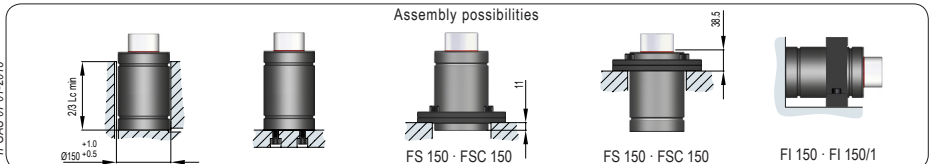
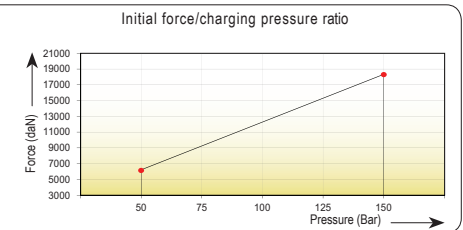
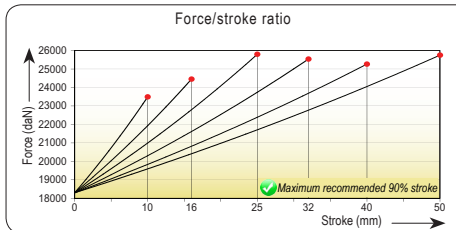

TPFGAS 07/01-2018