

- ▶ Noise reduction
- ▶ Vibration reduction
- ▶ Low contact force
- ▶ More efficient working environment

**TPNS**
**TPHT**

**Cylinders with impact damping**

Code	ØBody mm	Strokes mm	Fa daN	
TPNS 750.1	50	25 - 300	750	
TPNS 1500.1	75	25 - 300	1500	
TPNS 3000.1	95	25 - 300	3000	
TPNS 5000.1	120	25 - 300	5000	
TPNSR 1500	75	125 - 200	1500	✓
TPNSR 3000	95	125 - 200	3000	✓

i

All TPNS.1 gas springs are characterised by the fact that they reduce the impact force at the beginning of their working stroke. This series gradually increases force in such a way that in the first few millimetres of working stroke, the force is practically null.

The TPNS series is manufactured in ISO-norm dimensions and fixtures. They admit operation both in the autonomous mode and connected to a control panel.

- MICRO
- TITAN
- TPH
- TPS
- TPSP
- TPF
- TPK
- TPC
- TPR
- TPB
- TPHC
- TPA
- TPG
- TPCT
- TPSL
- STOP CYLINDER
- STOP CYLINDER
- TPSR
- TPSRs
- TPNS

Force Curve

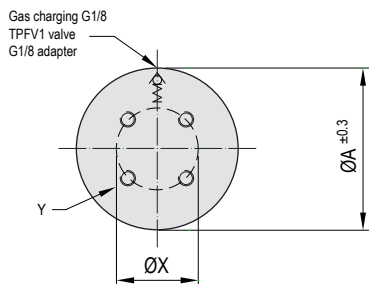
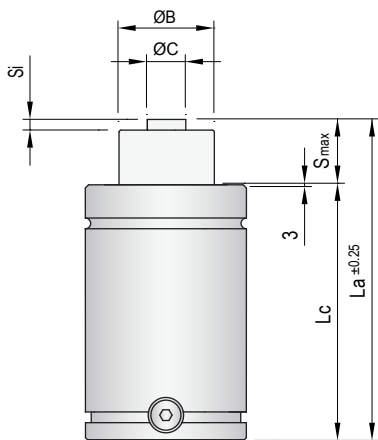
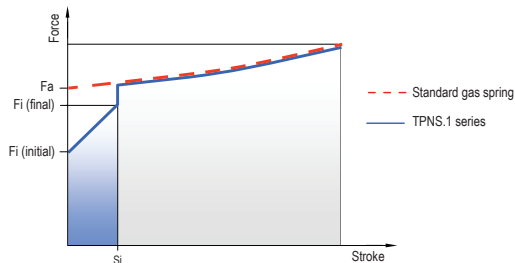

• Pressure medium	Gas Nitrógeno (N <sub>2</sub> )
• Max. charging pressure	150 Bar
• Min. charging pressure	50 Bar
• Operating temperature	0°C - 80°C
• Force increase by temperature	0,33 %/°C
• Max. stem speed	1 m/s



### ADVANTAGES

- ✓ Noise reduction
- ✓ Vibration reduction
- ✓ Progressive increase of force
- ✓ Interchangeability with ISO-standard gas springs
- ✓ Possibility of interconnection to a control panel
- ✓ Decrease in maintenance costs
- ✓ More efficient working environment

Code	Smax mm	La mm	Lc mm	Fi daN	Fa daN	Fc daN	Si mm	Ø A mm	Ø B mm	Ø C mm	Ø X mm	Y	P Bar	spm
TPNS 750x25.1	25	145	120	Initial 270	750 ±5% (20°C)	≈ 1000	6	50	30	14	20	2 x M8	105 (20°C)	65
TPNS 750x38.1	38	171	133											52
TPNS 750x50.1	50	195	145											43
TPNS 750x63.1	63	222	159											37
TPNS 750x80.1	80	255	175											31
TPNS 750x100.1	100	295	195											26
TPNS 750x125.1	125	345	220											22
TPNS 750x160.1	160	415	255											18
TPNS 750x200.1	200	495	295											14
TPNS 750x250.1	250	595	345											12
TPNS 750x300.1	300	695	395	10										
TPNS 1500x25.1	25	160	135	Initial 450	1500 ±5% (20°C)	≈ 2000	5	75	45	18	40	4 x M8	95 (20°C)	65
TPNS 1500x38.1	38	186	148											52
TPNS 1500x50.1	50	210	160											43
TPNS 1500x63.1	63	237	174											37
TPNS 1500x80.1	80	270	190											31
TPNS 1500x100.1	100	310	210											26
TPNS 1500x125.1	125	360	235											22
TPNS 1500x160.1	160	430	270											18
TPNS 1500x200.1	200	510	310											14
TPNS 1500x250.1	250	610	360											12
TPNS 1500x300.1	300	710	410	10										
TPNS 3000x25.1	25	170	145	Initial 750	3000 ±5% (20°C)	≈ 4000	5	95	60	22	60	4 x M8	105 (20°C)	55
TPNS 3000x38.1	38	196	158											44
TPNS 3000x50.1	50	220	170											37
TPNS 3000x63.1	63	247	184											31
TPNS 3000x80.1	80	280	200											26
TPNS 3000x100.1	100	320	220											22
TPNS 3000x125.1	125	370	245											18
TPNS 3000x160.1	160	440	280											15
TPNS 3000x200.1	200	520	320											12
TPNS 3000x250.1	250	620	370											10
TPNS 3000x300.1	300	720	420	8										
TPNS 5000x25.1	25	190	165	Initial 1200	5000 ±5% (20°C)	≈ 7000	5	120	75	32	80	4 x M10	110 (20°C)	55
TPNS 5000x38.1	38	216	178											44
TPNS 5000x50.1	50	240	190											37
TPNS 5000x63.1	63	267	204											31
TPNS 5000x80.1	80	300	220											26
TPNS 5000x100.1	100	340	240											22
TPNS 5000x125.1	125	390	265											18
TPNS 5000x160.1	160	460	300											15
TPNS 5000x200.1	200	540	340											12
TPNS 5000x250.1	250	640	390											10
TPNS 5000x300.1	300	740	440	8										

(Other models under order)

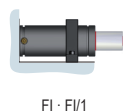
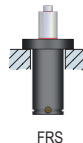
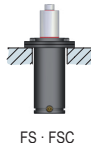
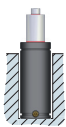
**Assembly possibilities**

**TPNS**

TPHT

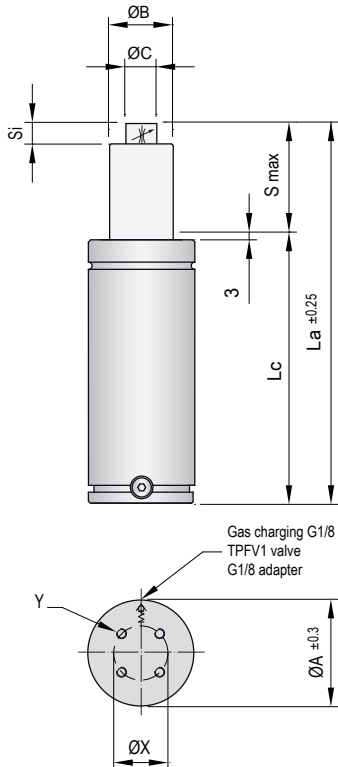

TPNSR gas springs are characterised by two functions:

- ▶ Reduction of initial working stroke force
- ▶ Reduction of stem speed during the expansion in the final stroke phase (Si)



Pressure medium	Gas Nitrógeno (N <sub>2</sub> )
Max. charging pressure	150 Bar
Min. charging pressure	50 Bar
Operating temperature	0°C - 80°C
Force increase by temperature	0,33 %/°C
Max. stem speed	1 m/s

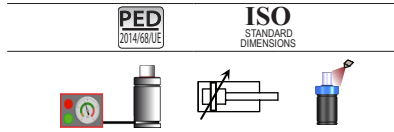

Operation Graph

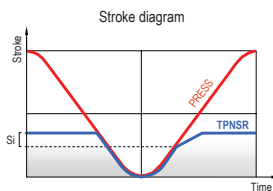
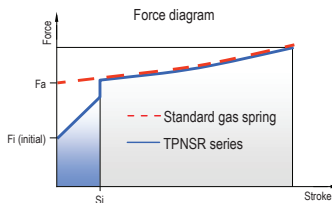

Code	Smax mm	La mm	Lc mm	Fi daN	Fa daN	Fc daN	Si mm	$\varnothing A$ mm	$\varnothing B$ mm	$\varnothing C$ mm	$\varnothing X$ mm	Y	P Bar	spm
TPNSR 1500x125	125	360	235		1500								95 (20°C)	22
TPNSR 1500x160	160	430	270	750	$\pm 5\%$	$\approx 2200$	15	75	45	22	40	4 x M8		18
TPNSR 1500x200	200	510	310											14
TPNSR 3000x125	125	370	245		3000								105 (20°C)	18
TPNSR 3000x160	160	440	280	1200	$\pm 5\%$	$\approx 4500$	24	95	60	32	60	4 x M8		15
TPNSR 3000x200	200	520	320											12

### Assembly possibilities

Follow guidelines  
Page 287

